



DOSATRON®

WATER POWERED DOSING TECHNOLOGY

14 GPM



D14 MZ 3000

D14 TMZ 3000

D14 MZ 2

D14 TMZ 2

D14 MZ 5

D14 TMZ 5

D 14 MZ 10

D 14 MZ 520

**owner's manual
manual de utilización
manuel d'utilisation**



DOSATRON®

WATER POWERED DOSING TECHNOLOGY

SERVICE CLIENTÈLE
CUSTOMER SERVICE
KUNDENBETREUUNG
SERVIZIO CLIENTI
DEPARTAMENTO CLIENTELA
KLANTENSERVICE

**NORTH & CENTRAL AMERICA :
DOSATRON INTERNATIONAL INC.**

2090 SUNNYDALE BLVD. CLEARWATER - FL 33765 - USA
Tel. 1-727-443-5404 - Fax 1-727-447-0591
Customer Service: 1-800-523-8499
<http://www.dosatronusa.com>



US/English..... Page 3

Spanish..... Seite 29

French..... Page 55

Enclosure / Anejos/ Annexes/..... 81

Quick start-up

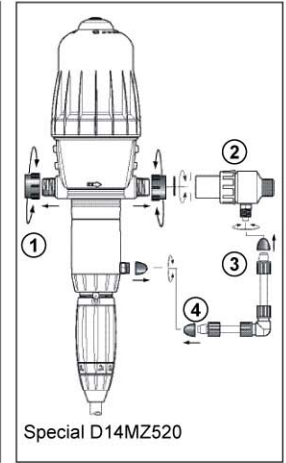
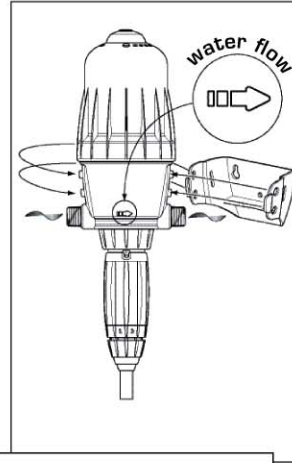
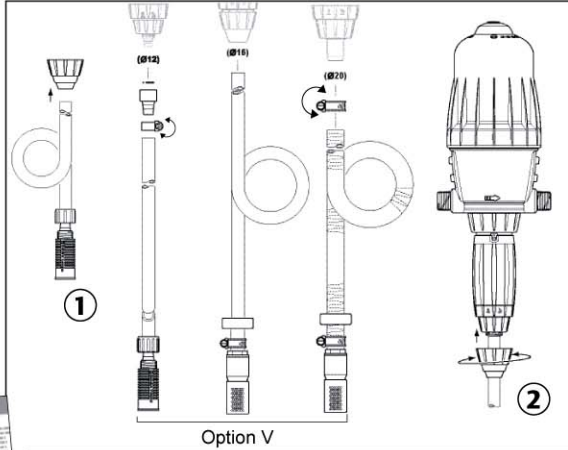
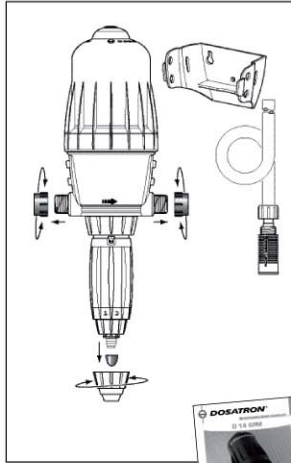

Maximum: 46 clicks/15 sec.*

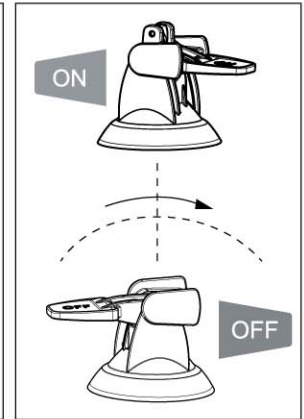
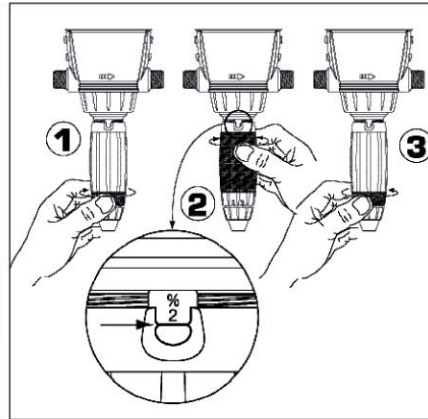
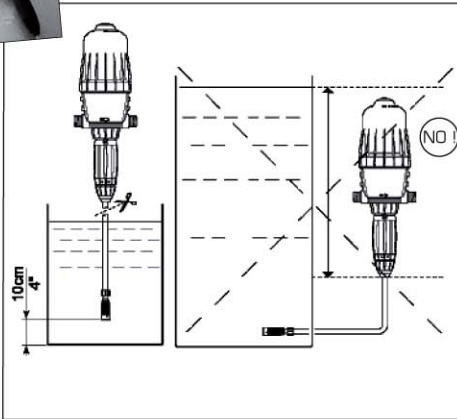
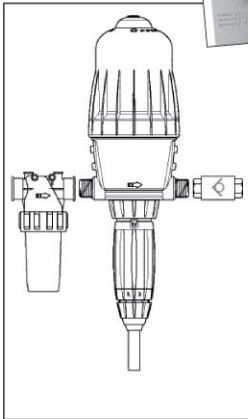

*D14MZ520 = 30 clicks/15 sec

SPECIFICATIONS

	D14MZ3000 D14T ⁽¹⁾ MZ3000	D14MZ2 D14T ⁽¹⁾ MZ2
Practical operating flow range:	
(1)	
(2)	
Maximum operating temperature:	
(1)	
(2)	
Operating pressure:	
PSI	4.3 - 85	4.3 - 85
bar	0.30 - 6	0.30 - 6
Externally adjustable or fixed injection rate:	
Ratio	1:3000 - 1:333	1:500 - 1:50
%	0.03 - 0.3	0.2 - 2
Concentrated additive injection:	
US GPM - MAXI	0.04	0.28
Mini l/h - Maxi l/h	0.0017	0.011
US Fl. oz/min - MINI	0.003 - 9	0.02 - 60
Connections (NPT/BSP male):	
Hydraulic motor capacity (for every 2 clicks of the piston):	

NOTE: The Dosatron is not preset, see chapter

UNIT SIZE		
Diameter: " [cm]	4 7/16 [11.2]	4 7/16 [11.2]
Total height: "[cm]	21[53]	19 3/32 [48.5]
Width: " [cm]	6 5/16 [16]	6 5/16 [16]
Weight: ± lbs [kg]	3.5 [1.6]	3.7 [1.7]

SHIPPING CONTENTS: 1 DOSATRON / 1 mounting bracket for DOSATRON / 1 suction tube of concentrated additive / 1 strainer / 1 injection suction tube for "IE" model / 1 owner's manual

D14MZ5 D14T ⁽¹⁾ MZ5	D14MZ10	D14MZ520 ⁽²⁾
..... 1/3 US Pint/min - 14 USGPM [10 l/h mini 3 m ³ /h maxi]		
..... 0.4 US Pint/min - 14 US GPM [100 l/h mini 3 m ³ /h maxi]		
..... 1/3 US Pint/min - 9 US GPM [10 l/h mini 2 m ³ /h maxi]		
..... 104 °F [40 °C]		
..... 140 °F [60 °C]		
..... 104 °F [40 °C]		
4.3 - 85	7 - 85	7 - 57
0.30 - 6	0.50 - 6	0.50 - 4
1:200 - 1:2	1:100 - 1:10	1:20 - 1:4
0.5 - 5	1 - 10	5 - 25
0.7	1.4	2.2
0.028	0.056	0.2818
0.05 - 150	0.1 - 300	0.5 - 500
..... 3/4" [Ø 20x27 mm]		
..... about 0.14 US Gallons [0.53 l]		

ADJUSTING THE INJECTING RATE

4 7/16 [11.2]	4 7/16 [11.2]	4 7/16 [11.2]
21 3/16 [53.8]	21 3/16 [53.8]	26 1/8 [66]
6 5/16 [16]	6 5/16 [16]	6 5/16 [16]
3.9 [1.8]	4.4 [2]	8.8 [4]

PACKAGE SIZE:

21 7/8" x 6 5/8" x 5 3/4" [55.2 x 16.5 x 14.5 cm]

PACKAGE WEIGHT: ~ 4.4 - 8.8 US lbs [2 - 4 kg approx]

Summary

INSTALLATION	PAGE
Precautions	9
Assembling the Dosatron.....	12
Connecting the external injection.....	14
Installation hints	17
 PUTTING INTO ORDER	
Using for the first time	18
 MAINTENANCE	
Recommendations.....	19
How to drain the Dosatron	19
International conversions.....	20
Fitting the suction tube	20
Adjusting the injection rate.....	20
Changing the motor piston.....	21
Changing seals in the injection assembly.....	22
 REFERENCE DESIGNATION	24
 TROUBLESHOOTING	25
 LIMITED WARRANTY	27

Precise, simple and reliable

A unique technology associating all dosing functions

Installed directly in the water supply line, the DOSATRON operates by using water pressure as the power source. The water activates the DOSATRON, which takes up the required percentage of concentrate. Inside the DOSATRON, the concentrate is mixed with the water. The water pressure forces the solution downstream. The dose of concentrate will be directly proportional to the volume of water entering the DOSATRON, regardless of variations in flow or pressure which may occur in the main line.

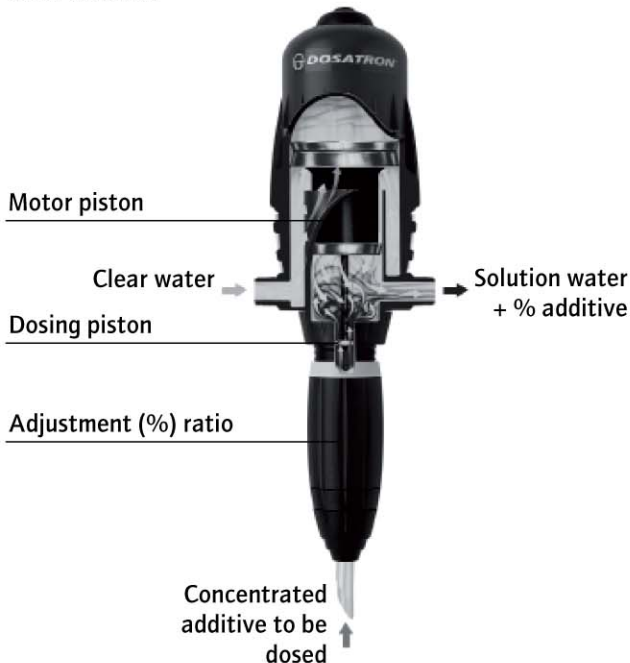

Installation

PRECAUTIONS

1 - GENERAL REMARKS

- When connecting a DOSATRON either to the public water supply or to its own water source, you must respect the regulations in force concerning protection of the source i.e. backflow prevention, etc.
- When connecting the DOSATRON to the water supply, ensure that the water flows in the direction of the arrows on the unit.
- In a case where the water installation is higher than the DOSATRON itself, there is a possible risk of water and concentrate flowing back through the DOSATRON. In this case, installing a non-return valve downstream is recommended.
- It is recommended that you should place an anti-siphon valve on the downstream side of the dosing pump in installations in which there is a risk of siphoning.
- Do not install the DOSATRON just above an acid container, (risk of acid fumes attacking the DOSATRON) and protect it from possible contact with corrosive products.
- Protect the DOSATRON from freezing temperatures by draining it and store it away from sources of

excessive heat.

- Do not install the DOSATRON on the suction side of the supply pump (risk of siphoning).

⚠ IMPORTANT ! Use no tool or metallic utensils.

- During any intervention the operator must stay in front of the DOSATRON and wear protective eyewear and gloves.

- It is the responsibility of the owner/operator to replace the injection seals annually to ensure precise injection.

The setting of the Dosatron's dosing rate is the sole responsibility of the user. The user has to respect the recommendations given by the manufacturer of the chemical product.

⚠ AVERTISSEMENT

When installing, operating, and maintaining the DOSATRON water powered metering pump, keep safety considerations foremost. Use proper tools, protective clothings, and eye protection when working on the equipment and install the equipment with a view toward ensuring safe operation.

1 - GENERAL REMARKS(cont...)

Follow the instructions in this manual and take additional safety measures appropriate to the liquid being pumped and the temperature of the water that powers the DOSATRON.

Be extremely careful in the presence of hazardous substances (e.g. corrosives, toxins, solvents, acids, caustic, flammables, etc.).

- Before applying any aggressive chemicals, please consult your distributor to confirm compatibility with the dosing pump.

- **When installing the DOSATRON on a hot water system (140°F/ 60°C max.), a dosing unit with "T"-option is required. High temperature increases the risk and the dangerousness of the substances mentioned above. It is strongly recommended to identify and label the dosing unit and the complete hot water installation as such, and to respect the corresponding regulations in force.**

IMPORTANT!

It is the responsibility of the owner/operator to check that the flow and pressure of the installation do not exceed the DOSATRON characteristics.

- Adjustment must be made when there is no pressure in the Dosatron.

- Turn off the water supply and allow the pressure to drop to zero.

- It is the responsibility of the owner/operator of the DOSATRON, to determine the correct amount of solution and injection ratio to obtain the desired result.

- An air inlet, an impurity or a chemical attack on seal can interrupt the dosing function. It is recommended to periodically check that the solution is being correctly drawn up into the DOSATRON.

- Change the suction tube as soon as it seems damaged by the chemical.

- Relieve the pressure after use (advised).

- Rinsing of the DOSATRON is required:

- . when changing chemicals,
- . before handling the DOSATRON, to avoid any contact with the chemical.
- All assembly should be done without tools, hand tighten only.

2 - WATER WITH HIGH PARTICLE CONTENT

- A (ex.: 50 mesh - 300 microns depending on your water quality) water filter must be installed upstream from the DOSATRON (see accessories), if a filter is not installed abrasive substances will cause the DOSATRON to deteriorate prematurely.

3 - WATER-HAMMER /

EXCESSIVE FLOW

- For installations subject to water hammer a protection device such as a check valve or union ball check must be fitted (pressure/flow control system).

- For automatic installations, slow opening and closing solenoid valves are preferable.

- In an installation where a DOSATRON serves several sectors, the closing of one sector and the opening of another sector must be done at the same time (simultaneous operation of the solenoid valves).

4 - INSTALLATION LOCATION

- The location of the DOSATRON and concentrate container should be accessible, but should never present a risk of pollution or contamination.

- It is recommended to label all water lines with a warning about the injected solution i.e.

 **IMPORTANT ! Not For Human Consumption.**

5 - MAINTENANCE

- Rinse the injection areas after using the DOSATRON. To do this, insert suction tube into a container of clean water and inject about 1/4 liter [8 1/2 US Fl.oz].

- Routine maintenance once a year will add to the life of your DOSATRON. Replace the injection

seals as well as the suction hose annually to ensure proper injection.

6 - SERVICE

- This DOSATRON was tested prior to packaging.

- Complete maintenance and seal kits are available.

- Call your DOSATRON distributor for service or parts.

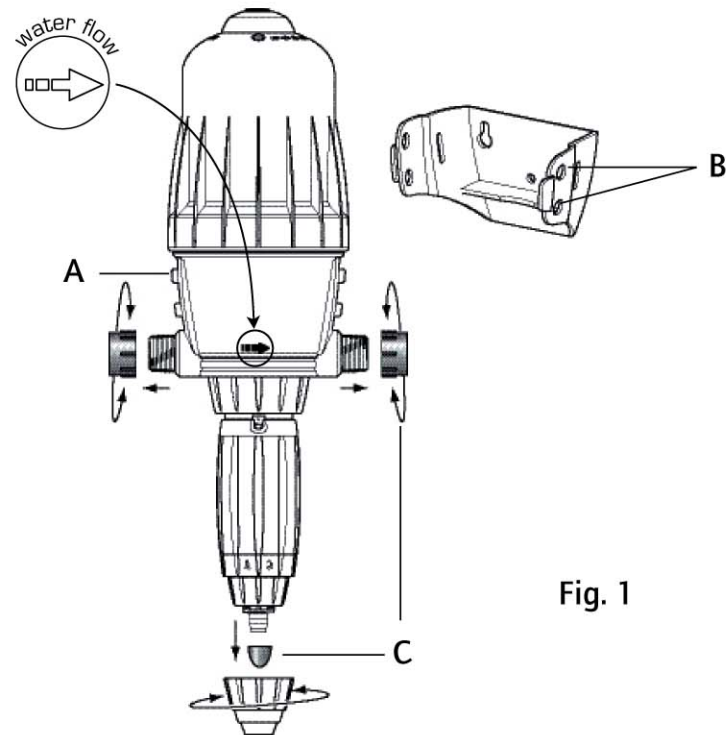

Fig. 1

ASSEMBLY SHOULD BE CARRIED OUT WITHOUT THE USE OF TOOLS

The DOSATRON is delivered with :

- a mounting bracket,
- a suction tube with a strainer.

The bracket enables the DOSATRON to be fixed to a wall.

Snap the DOSATRON into the bracket by fitting the two lugs on one side of the body (**Fig. 1-A**) into the corresponding holes in the bracket (**Fig. 1-B**), and springing the bracket arms apart until the other 2 lugs click into place.

Remove the plastic caps (**Fig. 1-C**) which block the inlet and outlet of your DOSATRON before connecting to the water supply.

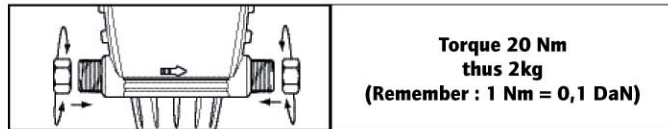
RECOMMENDATIONS

The DOSATRON can be connected to the water supply by means of $\varnothing 3/4"$ [20 x 27mm] bore flexible hose and hose tail fittings with hose clips. Make certain that the water flows in the direction of the arrows on the motor body.

The DOSATRON is delivered with a suction tube (cut it to the needed length) enabling its use with a large capacity concentrate container.

The tube must be fitted with its strainer and weights.

The instructions for fitting the tube are to be found in the specific chapter.

NOTE : The maximum suction height is 13 vertical feet (4 meters).

Fit the tube, equipped with its strainer and its weight, and immerse it in the solution to be injected.

CONNECTING THE EXTERNAL INJECTION (IE)

In order to use corrosive concentrates, the external injection model DOSATRON is also delivered with an external injection hose.
CAUTION screw in the components carefully !

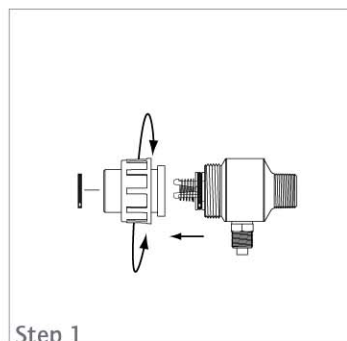
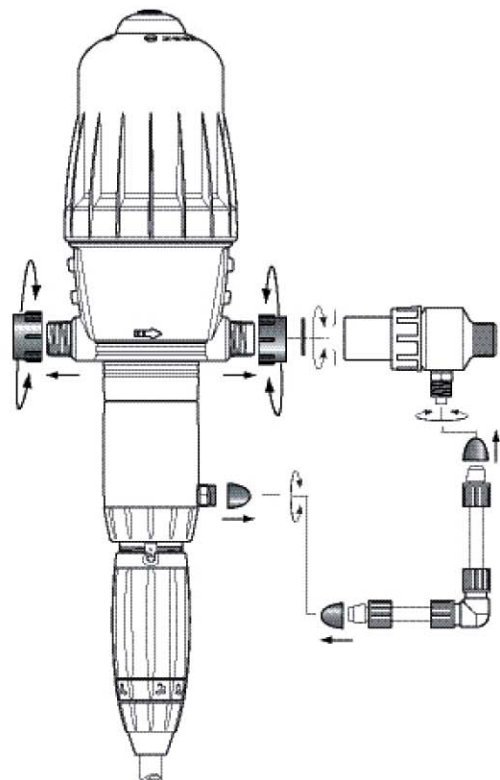

Step 1

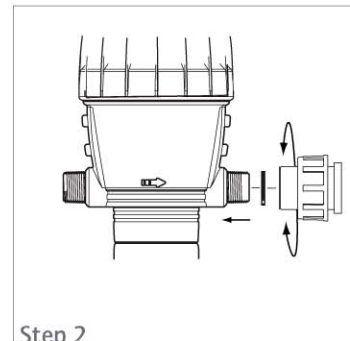

Step 2

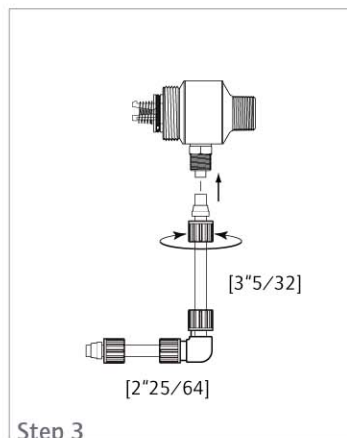

Step 3

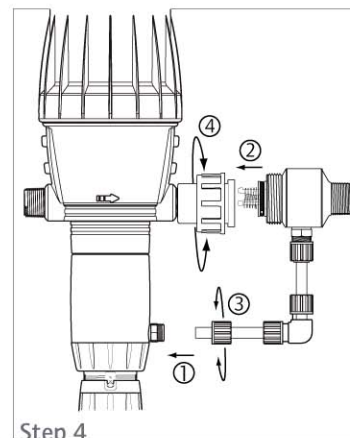

Step 4

IMPORTANT ! - Do not put the suction tube strainer on the bottom of the stock solution container. The strainer must be suspended at least 4" [10cm] above the bottom of the tank to avoid sucking up the insoluble particles that may damage the injection assembly (Fig.2).

- Do not put the strainer on the ground.

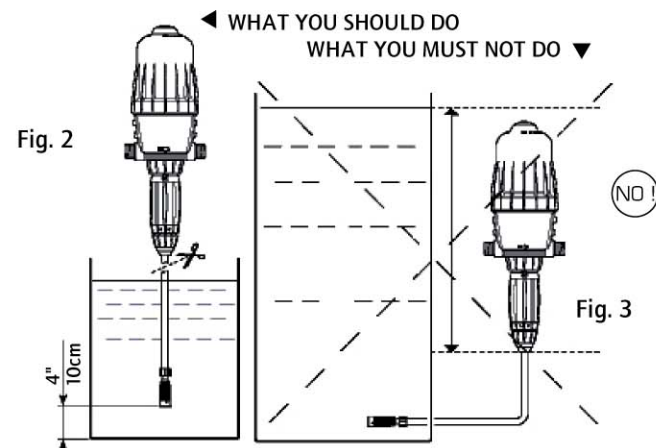

Under no circumstance should the solution level be above the water inlet of the DOSATRON (to avoid siphoning situations) (Fig. 3).

The DOSATRON can be connected to the main water line **directly** (Fig. 4) ; on a **by-pass** (Fig. 5), recommended.

If your flow rate is above the operating limits of the DOSATRON, see **EXCESSIVE FLOW**.

To prolong the working life of the DOSATRON it is advisable to install a filter (ex: 300 mesh - 60 microns depending on your water quality) upstream.

This is imperative if the water contains impurities or particles, especially if the water comes from a well.

A filter is recommended and required for the warranty to be valid.

Installing the DOSATRON on a bypass enables clean water to be supplied without operating the DOSATRON and the DOSATRON to be easily dismantled.

When connecting an installation to the public water supply, you must respect the rules and regulations in force in the country.

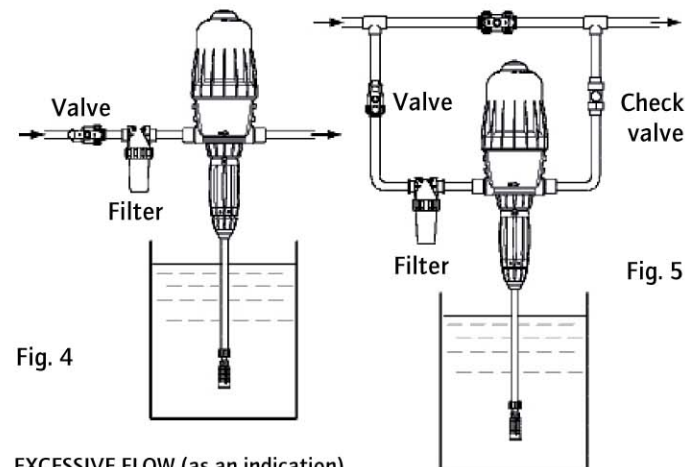

EXCESSIVE FLOW (as an indication)

If your DOSATRON clicks more than **46 times**, that is **23 cycles in 15 seconds***, you are close to the superior flow limit. If you need more flow, you must install a DOSATRON with a superior capacity of flow.

*D14MZ520 = 30 times, 15 cycles

Putting the DOSATRON into order

USING FOR THE FIRST TIME

- Partially open the water inlet valve.
- Press the bleed button on the top of the DOSATRON (Fig. 6).
- When a constant flow of water is seen coming from around the bleed button (no more «spitting» of air), release the button.
- Open the water inlet valve slowly, the DOSATRON is self-priming.
- Operate the DOSATRON until the product to be injected is drawn up into the doser body (the product is visible through the plastic tube).
- The DOSATRON makes a characteristic "click-clack" noise when working.

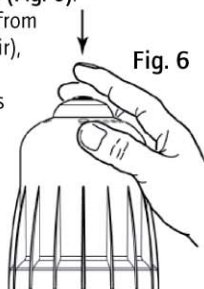

NOTE: The time required to prime the suction tube depends on the water flow-rate, the ratio setting and the length of the suction tube. To bleed the air from the suction tube and accelerate the priming, set the injection rate at maximum. Once the DOSATRON is primed, adjust to the required injection rate (see § ADJUSTING THE INJECTION RATE).

The DOSATRON may be fitted in its upper part with the function by-pass (optional equipment):

- By-pass in **ON**, the DOSATRON works and the concentrate is drawn up.
- By-pass in **OFF**, the DOSATRON is stopped and does not draw up the product.

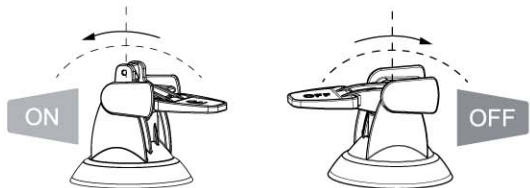

Maintenance

RECOMMENDATIONS

1 - When using soluble products to be made up into solutions, we recommend the periodic dismantling of the entire dosing part (see : § CLEANING AND REFITTING THE SUCTION VALVE, § CHANGING SEALS IN THE INJECTION ASSEMBLY).

Thoroughly rinsing all the elements of the dosing part with water and re-assembling them after having previously lubricated the seal (Fig. 7) with a silicone lubricant, in the case of difficulty in re-fitting.

2 - Before putting the DOSATRON into operation after a non-use period, remove the motor piston and soak it into lukewarm water < 104° F [40° C] overnight. This helps to dissolve any deposits which may have dried onto the piston motor.

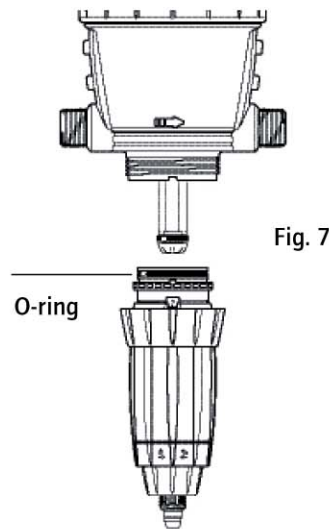

HOW TO DRAIN THE DOSATRON (in case of freezing temperature)

- Turn off the water supply and let the pressure drop to zero.
- Remove the injection assembly, see § CHANGING THE MOTOR PISTON.
- Remove the bell and the motor piston.
- Disconnect the water inlet and outlet fittings.
- Remove the lower pump body from the mounting bracket and empty any remaining water.
- The DOSATRON can now be reassembled, having first cleaned the seal.

Principle : Setting at 1% $\Rightarrow 1/100 = 1$ part of concentrate for 100 parts of water.

Ex. : Setting at 2% $\Rightarrow 2/100 = 2$ parts of concentrate for 100 parts of water.

Ratio $\Rightarrow 1/50$.

FITTING THE SUCTION TUBE

If the DOSATRON has already been used, please **imperatively** refer to § PRECAUTIONS.

- Unscrew the nut (Fig. 11) at the bottom of the injection assembly and put it onto the tube.

- Push the tube onto the barbed fitting as far as it will go and screw up the nut by hand (Fig. 12).

Fig. 11

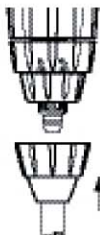
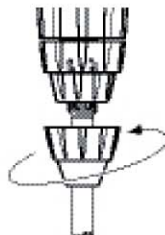

Fig. 12



ADJUSTING THE INJECTION RATE (with pressure off)

IMPORTANT ! Use no tools.

Adjustment must be made when there is no pressure in the DOSATRON.

- Turn off the water supply and allow the pressure to drop to zero.

- Unscrew the blocking ring (Fig. 13).

- Screw or unscrew the adjusting nut in order to line up the 2 peaks of the eyelet with the desired ratio on the scale (Fig. 14).

- Tighten the blocking ring (Fig. 15).

Fig. 13

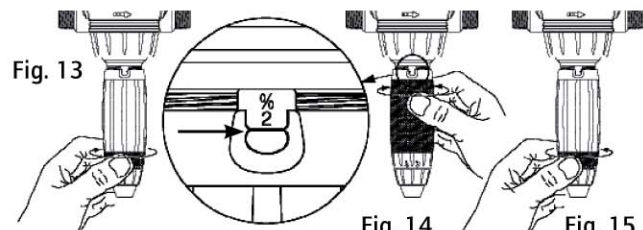

Fig. 14

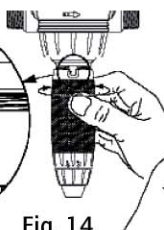

Fig. 15



CHANGING THE MOTOR PISTON (with pressure off)

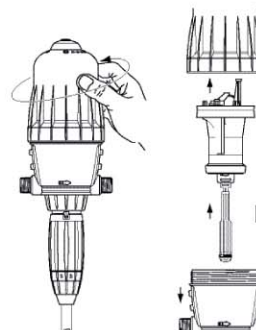

Fig. 16



Fig. 17

- Turn off the water supply and allow the pressure to drop to zero.

- Unscrew and remove bell-housing by hand (Fig. 16).

- Remove the motor piston (Fig. 17) by pulling it up.

- Rod and plunger piston are fixed to the motor piston and taken out simultaneously.

- Change and reassemble in the reverse order to the above.

- Refit the bell-housing (take care not to damage its seal) and tighten by hand.

CHANGING THE MOTOR PISTON D14MZ520 (with pressure off)

Fig. 18

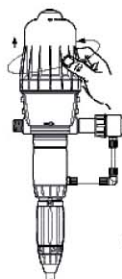

Fig. 19

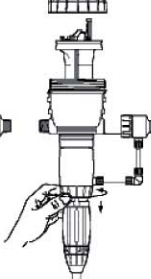

Fig. 20

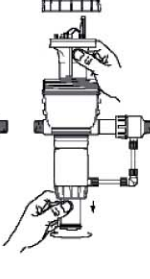
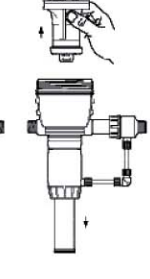

Fig. 21



- Shut the water supply and let the pressure drop to zero.

- Unscrew the bell by hand (Fig. 18) and remove it.

- Unscrew the fixing nut of the dosing part (Fig. 19) and remove it.

- Retain the motor piston while turning

the plunger piston 1/4 turn (Fig. 20).

- Change parts and reassemble in the reverse order to the above.

- Refit the bell taking care not to damage its seal and screw by hand (Fig. 21).

- Refit the dosing part assembly.

Frequency : Once per year.

IMPORTANT ! Use no tool or metallic utensils

ADVICE: Before dismantling any part of the injection assembly it is advisable to operate the DOSATRON, injecting clean water so as to rinse through the injection system. In this way, risks of contact with concentrated solutions in the injection assembly are minimized.

During any such intervention, wear protective eyewear and gloves !

METHOD OF REMOVING SEAL

Fig. 22 : Between finger and thumb, pinch the component and the seal ; push towards one side to deform the seal.

Fig. 23 : Increase the deformation to grip the part of the seal thus exposed and pull it out of its groove.

Clean the seal seating without any tools.

Refitting is done by hand.

It is very important that the seal is not twisted once in place as this would impair its efficiency.

Fig. 22



Fig. 23



Please refer to the drawings of the different models at the end of this manual

- **Change the seals once a year.**
- Turn off the water supply and allow the pressure to drop to zero.
- Take off the suction tube of product (Fig. 24).
- Unscrew the retaining ring (Fig. 25).
- Pull downwards to remove the injection assembly (Fig. 26).
- Change the seals, the suction valve and the barbed fitting.
- Re-assemble in the reverse order to the above **by hand**.

Fig. 24

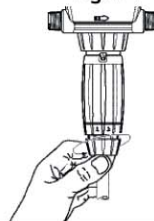

Fig. 25

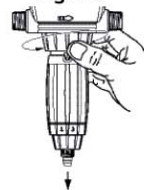
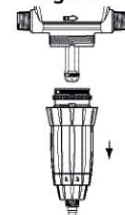

Fig. 26



CLEANING AND RE-ASSEMBLING THE SUCTION VALVE SEAL

- Turn off the water supply and allow the pressure to drop to zero.
- Unscrew the nut and pull downwards to remove the suction tube (Fig. 27).

Unscrew and take off the suction valve retaining nut (Fig. 28), pull out the valve assembly, dismantle the valve and thoroughly rinse the separate components in clean water.

Put the valve components in the order shown in the diagram (Fig. 29).

Re-assemble the components in the reverse order to the dismantling process.

Fig. 27



Fig. 28



Fig. 29

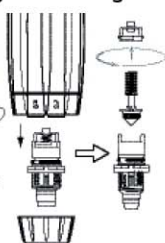

Reference Designation

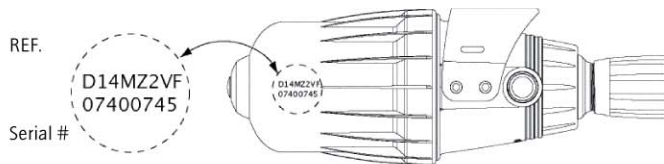

REF. :	Serial #:
EXAMPLE	D14 T RE 1:200 IE BP V AF P II
Type of DOSATRON	
Temperature	
MZ : adjustable	
Dosage (ratio or %)	
IE : External Injection	
BP : integrated by-pass	
V : Viscous Products (> 400 cPs)	
Dosing Seals: AF = PH 7-14 VF = PH 1-7 K = strong acids (>15%)	
Color : - = Blue [PP] P = White [PVDF] R = Red [PP] V = Green [PP] J = Yellow [PP] O = Orange [PP]	
Other extensions (consult us)	

Troubleshooting

SYMPTOM	CAUSE	SOLUTION
Motor piston		
DOSATRON does not start or stops	Piston stalled	Reset piston, by hand
	Air has not been bled from unit	Bleed air from unit, by bleed button
	Maximum flow exceeded.	1. Reduce flow, restart unit 2. Unscrew the bell. Take off the piston and check piston valves seals to ensure correct position
Motor piston is damaged		Return unit to your service center for repair
Injection		
Water flowing back into concentrate container	Contaminated, worn, or missing check valve parts	Clean or replace it
No suction of concentrate	The piston motor has stopped	See Motor piston section
	Air leak (inlet) in the suction tube	Check the tightness between nut and suction hose
	Blocked suction tube or clogged strainer	Clean or replace it
	Missing or worn suction check valve seal	Clean or replace it
	Missing or worn plunger seal	Clean or replace it
	Worn injection stem	Replace it

Limited warranty

SYMPTOM	CAUSE	SOLUTION
Injection		
Under injection	Suction of air	1. Check the tightness of the nuts in the injection area 2. Check suction tube
	Dirty or worn check valve seal.	Clean or replace it.
	Maximum flow exceeded (cavitation)	Reduce flow
	Worn plunger seal	Replace it
	Worn injection stem	Replace it
Leaks		
Leaks in the vicinity of the fixing ring under the body housing	Injector sleeve seal is damaged or positioned incorrectly	Replace it
Leaks between the setting sleeve and the blocking ring	Injector stem seal damaged, positioned incorrectly or missing	Replace it
Leaks between the body and bell	Pump body seal is damaged, positioned incorrectly or missing	Unscrew the bell, clean the seal seating, replace or change the seal. Position correctly the bell.

**THE MANUFACTURER
DECLINES ALL RESPONSIBILITY IF THE DOSATRON
IS USED IN CONDITIONS THAT DO NOT CORRESPOND
TO THE OPERATING INSTRUCTIONS AS INDICATED
IN THIS MANUAL**

DOSATRON INTERNATIONAL S.A.S. will provide for replacement of all parts shown to be defective in material or workmanship during a period of twelve months from the date of purchase by the original purchaser. To obtain warranty replacement of a part, the DOSATRON must be returned with original proof of purchase receipt to the manufacturer or authorized distributor and thereafter recognized as defective after examination by the technical services of the manufacturer or distributor. The DOSATRON must be flushed of any chemical and sent to the manufacturer or distributor prepaid, but will be returned free of charge once repairs are made if found to be covered by the warranty. Any repairs made under warranty will not extend the initial warranty period.

This warranty only covers circumstances where the part has failed due to defects caused by the manufacturing process. This warranty is invalid if the defects are found to be due to the product's misuse, inappropriate use of tools, lack of maintenance or defective installation or environmental accidents or corrosion by foreign bodies and liquids found within or in proximity to the DOSATRON. Before using any aggressive chemicals, please consult your distributor to confirm compatibility with the dosing pump.

The seals and "o-rings" are not covered under warranty, nor is damage to the DOSATRON caused by water impurities such as sand. A filter (ex.: 300 mesh - 60 microns depending on your water quality) must be used in front of the DOSATRON for the warranty to be valid. DOSATRON INTERNATIONAL S.A.S. declines any responsibility if the DOSATRON is not used in compliance with the operating instructions and tolerances as indicated in this owner's manual.

This warranty gives you specific legal rights and you may also have other rights which vary from state to state. But any implied warranty or merchantability or fitness for a particular purpose applicable to this product is limited in duration to the time period of this written warranty or any implied warranty.

There is no warranty express or implied relating in any way to products used in conjunction with DOSATRON INTERNATIONAL S.A.S. products.

The manufacturer or authorized distributor shall not be liable for incidental or consequential damage, such as any economic loss, resulting from breach of this written warranty or any implied warranty.

There are no warranties, express or implied, which extend beyond those described above.

A SIMPLE METHOD

THE DOSATRON IS COMPOSED OF:

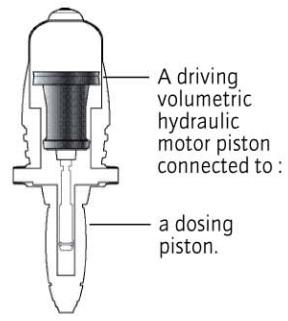

In its up and down movement, you can hear the motor piston click:

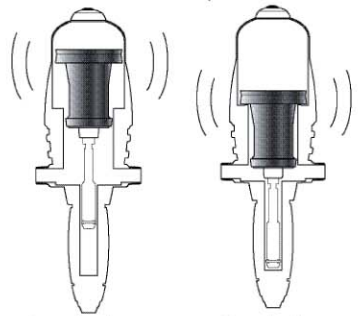

2 clicks = 1 motor cycle
= The stroke volume

The speed of the motor is proportional to the flow of water passing through the system.

■ Calculation of water flow in l/h =

$$\frac{\text{Number of clicks in 15 seconds}}{2} \times 4 \times 60 \times 0.45$$

Calculation for 1 minute (4)
 Calculation for 1 hour (60)
 Stroke volume in litres (0.45)
 2 clicks = 1 cycle

■ Calculation of water flow in GPM =

$$\frac{\text{Number of clicks in 15 seconds}}{2} \times 4 \times 0.45 \div 3.8$$

Calculation for 1 minute (4)
 Stroke volume in litres (0.45)
 Conversion from litres to gallons (3.8)
 2 clicks = 1 cycle

NOTA : This method of calculation cannot replace a flow meter. It is given only as an approximate guide.